

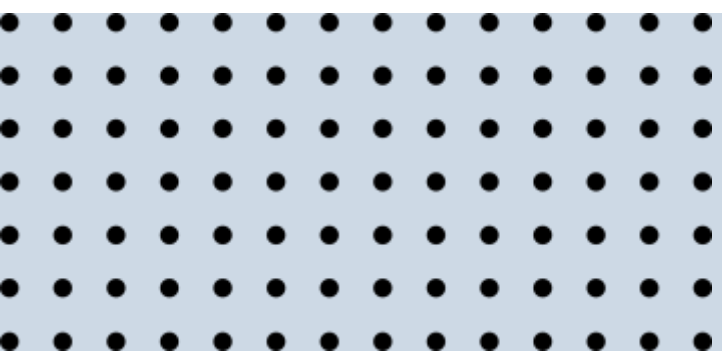

成心科技

SUCCESSFUL HEART TECHNOLOGY

회사소개서

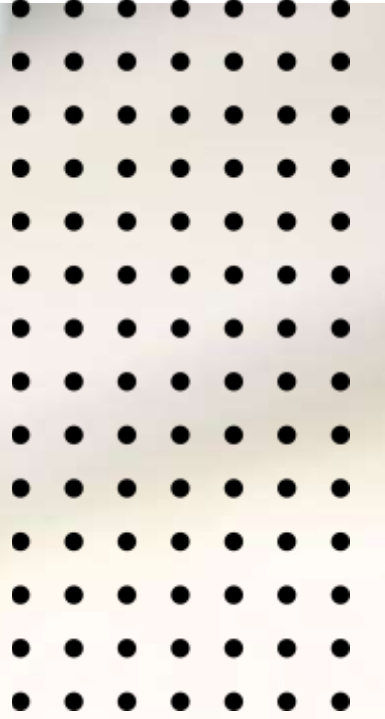

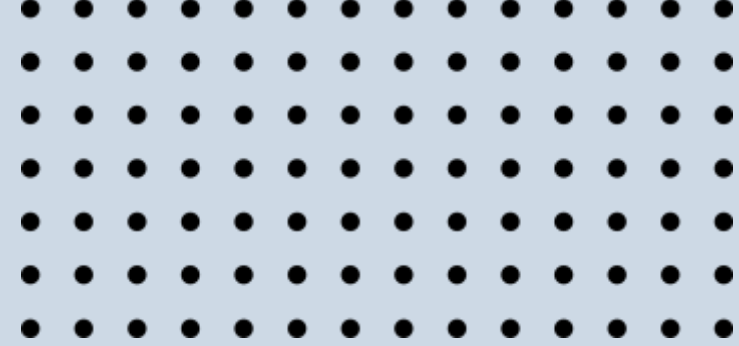

SUCCESSFUL HEART TECHNOLOGY

대표이사 : 김상훈 / 구국위

설립일자 : 2009.11

자본금: US\$ 3,150,000

사업분야 : 반도체/Display-Parts 판매&수리, 설비 판매& Modify

사원수 : 136명

Headquarters : No.38, Qunyi Rd., Zhunan Township, Miaoli County , Taiwan 35059

China office :

No. 1006, Xinghui Center, Changping Town, Dongguan City, Guangdong Province
2F-201, No.1883 Jiyin Avenue, Jiangning District, Nanjing City

Korea office : 901-9F, 253, Pangyo-ro, Bundang-gu, Seongnam-si, Gyeonggi-do, Republic
of Korea 13486

Singapore office : 1 YISHUN INDUSTRIAL STREET1# 04-19 A'POSH BIZHUB SINGAPORE
(768160)

Japen Office : 2-6-18 Minamikashiwa, Kashiwashi, Chiba 277-0855 JAPAN

Vietnam Office : Floor 3, B3-11 Vinhomes Gardenia, Ham Nghi, Cau Dien ward, Nam Tu
Liem district, hanoi city, Vietnam

COMPANY HISTORY



2009

- GCT Repair center 설립



2010

- SHT 설립



2011

- SHT Korea 설립
- CMO/AUO Vender code
- UMC/Micron/
Winbond Vender code



2012-2013

- Jiufeng 설립
- AKT OEM
Vender code



2014-2015

- SHT 본사 이전
- MECHARONICS SZ 설립
- CSOT/TIANMA Vender code
- GCT ISO 9001/14001 인증
- UMC 12X/TLURY/ APPLE
Vender code



2018-2019

- TSMC Vender code
- GCT Chiller Repair
분문 설립
- Vietnam Office 설립
- CXMT/JHICC Vender
code
- HKC Vender code



2020

- Water treatment
engineering 설립
- USCXM Vender
code



2021

- Xiamen Office 설립
Repair center
- MECHARONICS SZ
이전
- SHT ISO 9001 인증
- GCITCXM ISO
9001/14001 인증



2022

- SHT Turbo & Cryo
PUMP Repair center
- NanJing Office 설립
- TSMC Nanjing /YMTC
/CHOT Vender code





2024-Now

- Singapore Office 설립
- Japan Office 설립

LOCATION



TAIWAN

-  Zhunan Headquarters & Repair Center
-  Tainan Office & Chiller Repair Center

KOREA

-  Korea office

SINGAPORE

-  Singapore office

CHINA

-  Shenzhen Office
-  Xiamen Office & Repair Center
-  NanJing Office & Repair Center
-  ChongQing Office

JAPAN

-  Japan office

VIET NAM

-  Hanoi office

Sales Record

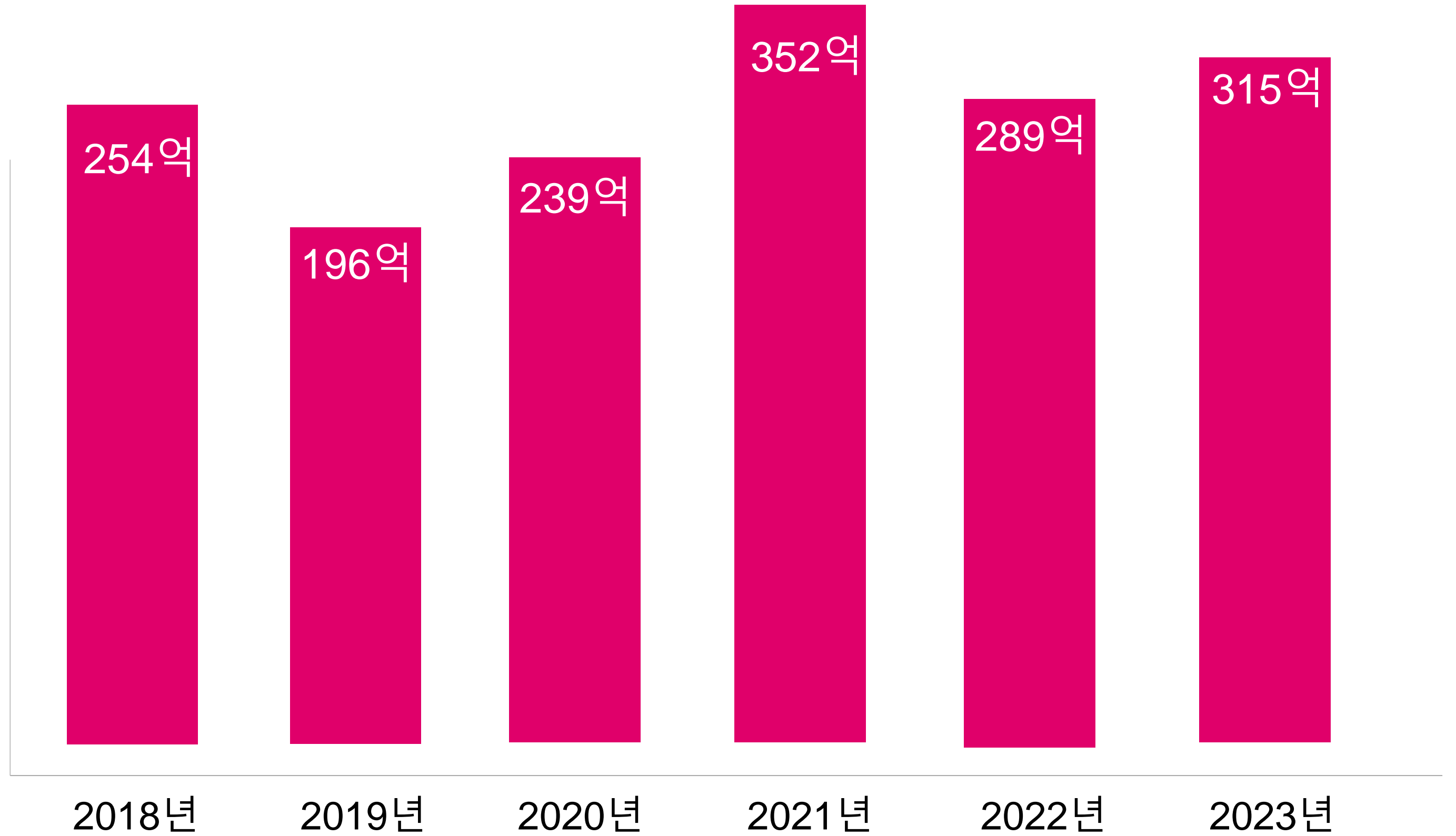
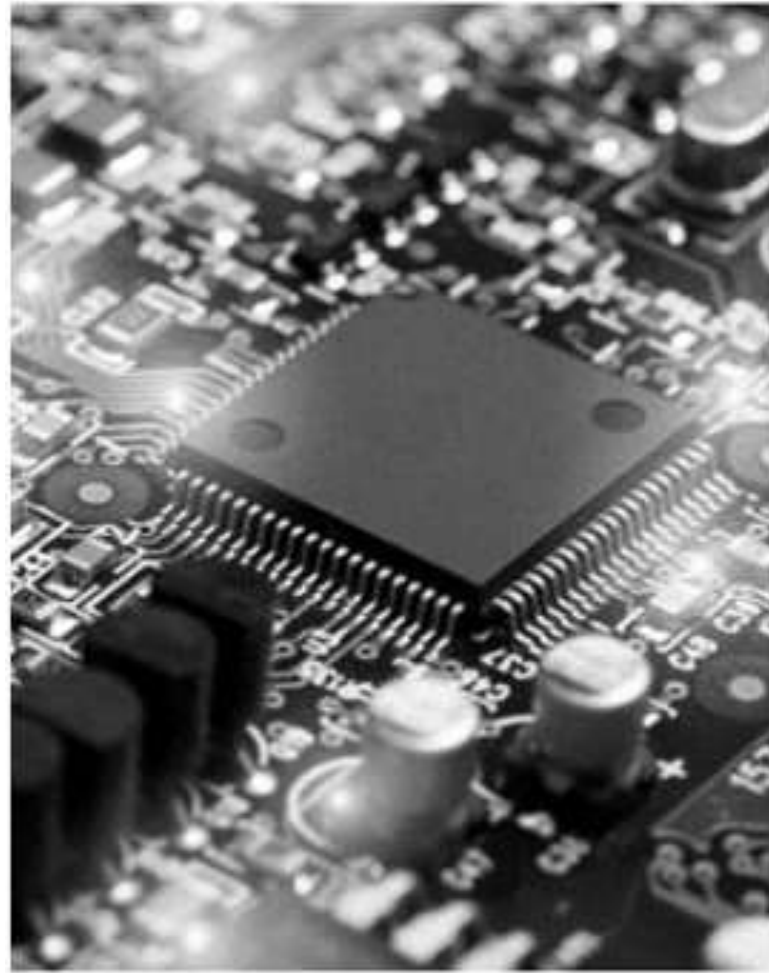

HEADQUARTERS

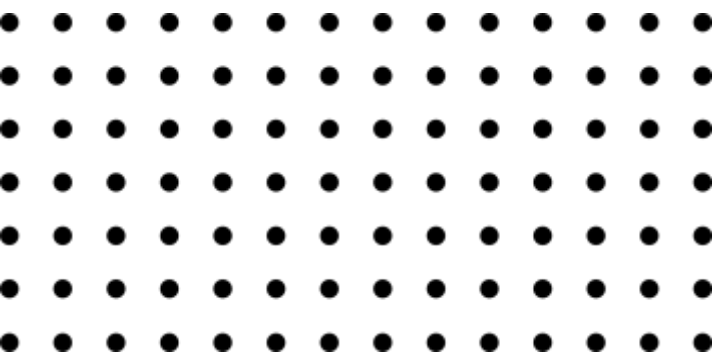

Singapore Office & Repair Center



Vietnam Office

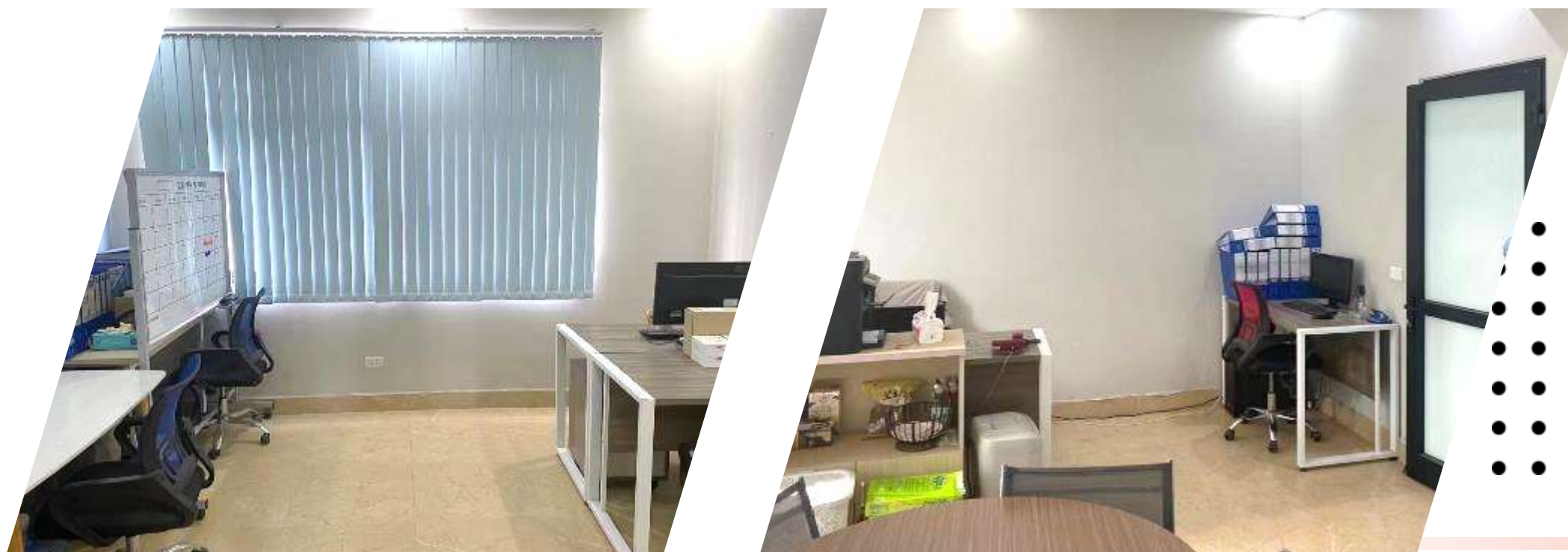

Xiamen Office & Repair Center



NanJing Office & Repair Center

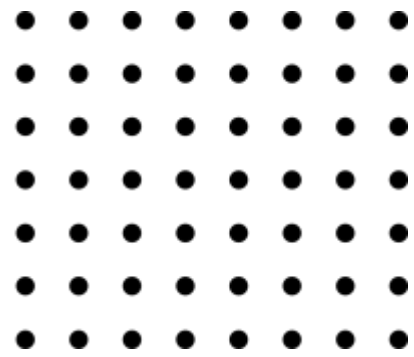

Product applications

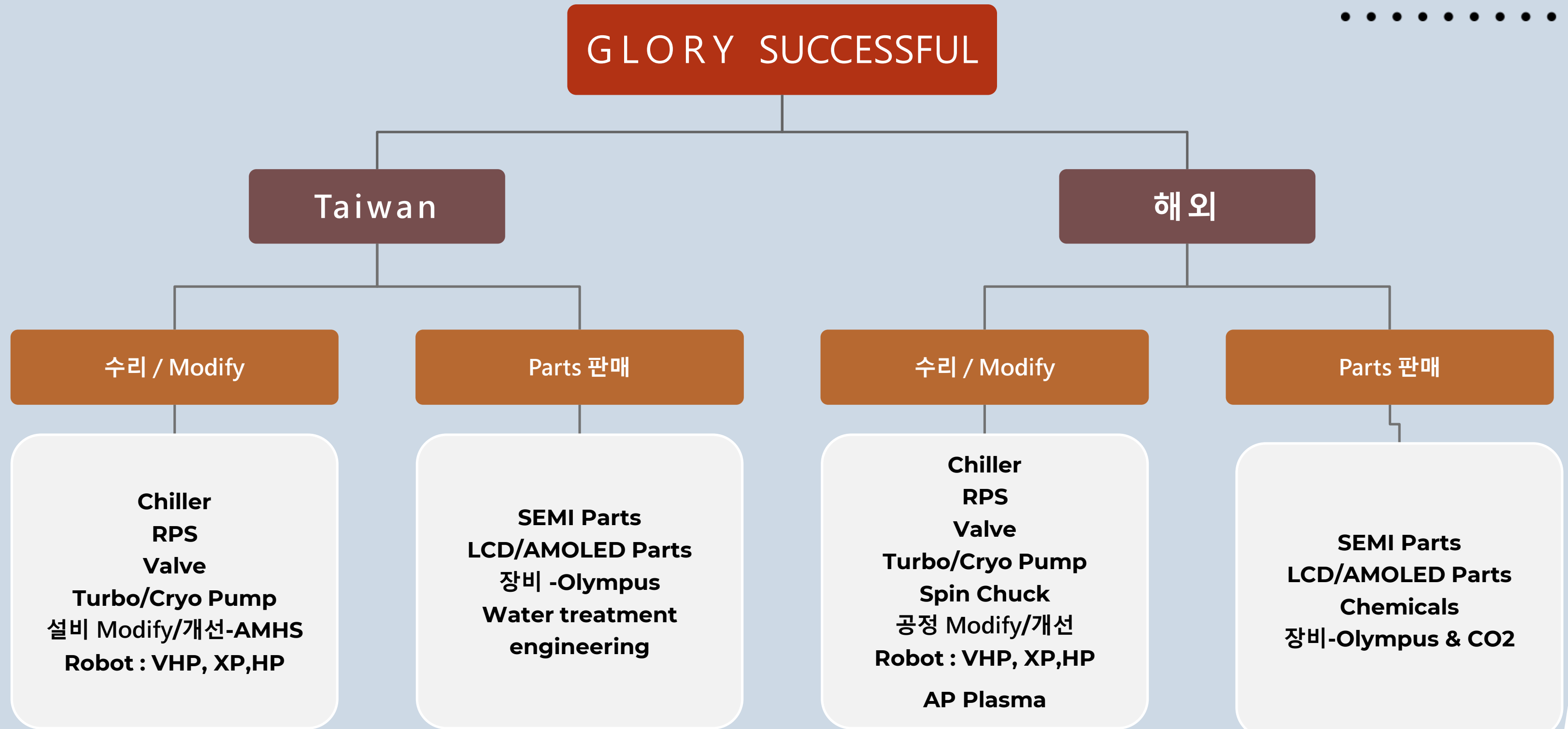

SEMI Parts -AIN Heater

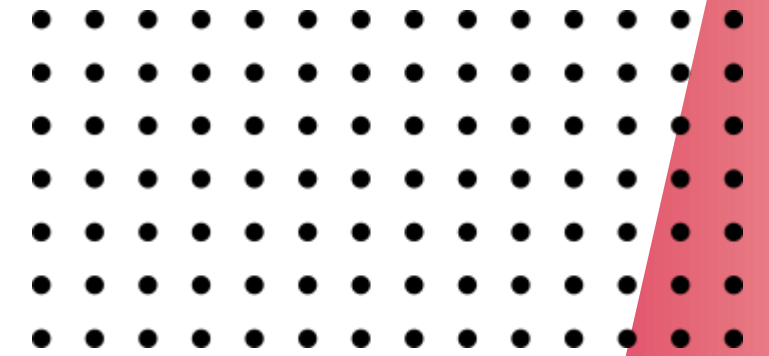

12" AMAT Producer
AIN heater



8" AMAT Producer
AIN heater



8" AMAT Centura
AIN heater

SEMI Parts -Al Heater

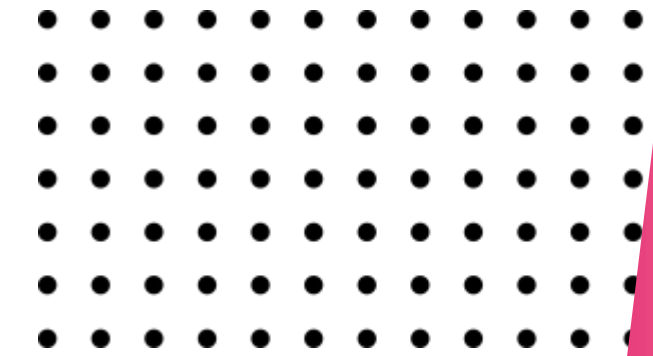

Pedestal 12"



CVD Heater 12"

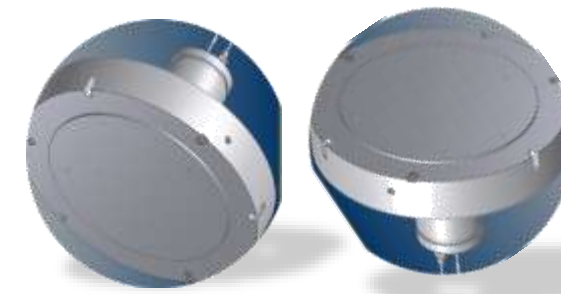

Vector
Heater 12" AIF extreme



Pedestal 8"



Pedestal 12" ATM



Vector
Heater 12" Normal
(AIF Coating Type)

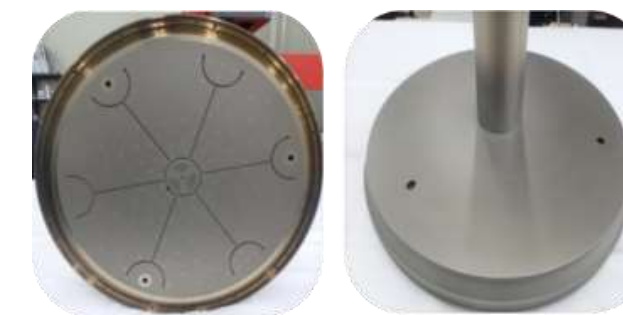

12" AMAT ENDURA MCA Heater
(0040-91179 / 2nd new/SUS Heater)

SEMI Parts -Al Heater

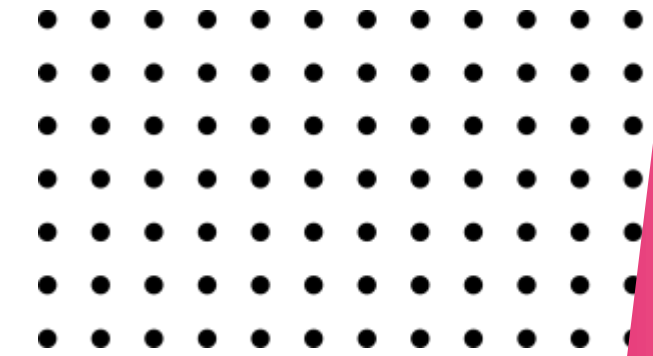

FORGED DXZ 8"

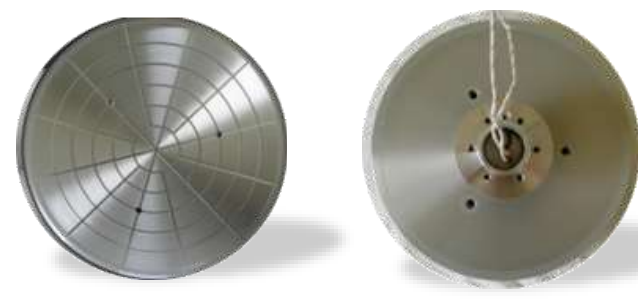

DAS 2000

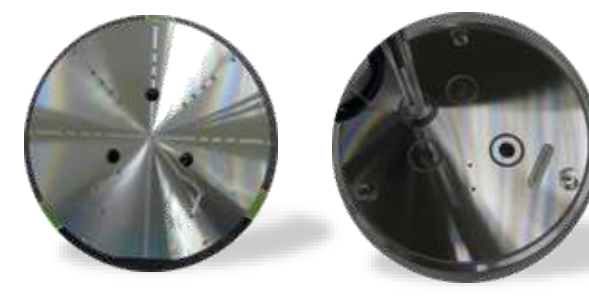

GASONIC 8"



8" WXZ



PLUS TXZ 8"

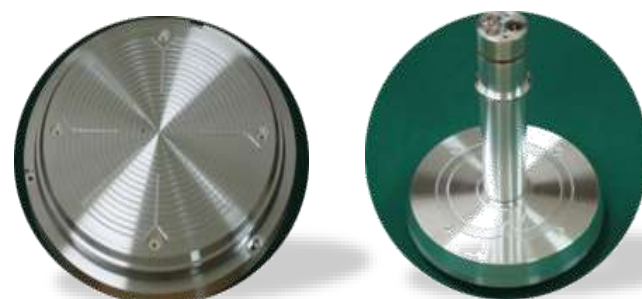

CPR 8"

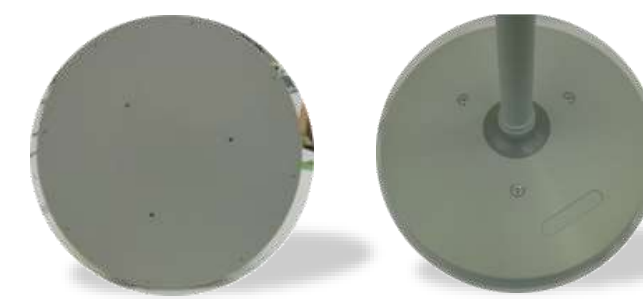

ATTO 8" 12"

SEMI Parts - 8" & 12" ESC

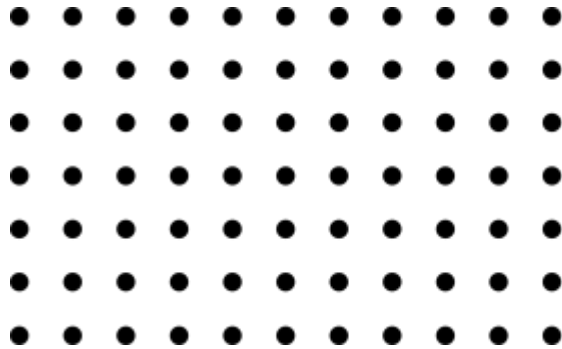

12" AMAT MCA High & Low Temp ESC(Repair)

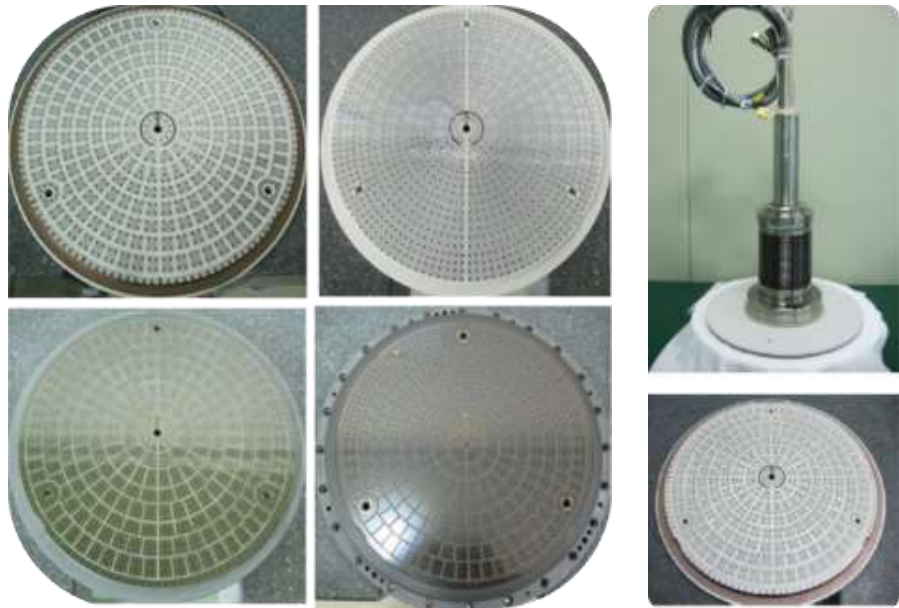

12" LAM Al2O3 Plate type



12" AMAT DPS



12" TEL RK&LK & NV



12" AMAT Producer



12" AMAT E-MAX

SEMI Parts- Quartz & Silicon & SIC

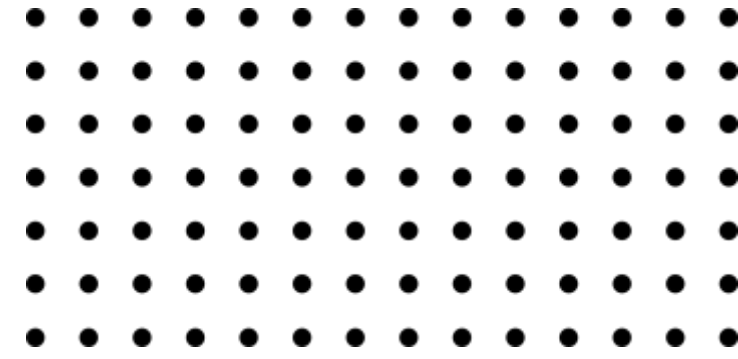

12" & 8" Quartz parts



12" & 8" Si Cathode & Ring



CVD SIC ring



Focus ring



Outer cel



Inner cel

SEMI Parts- Ceramic

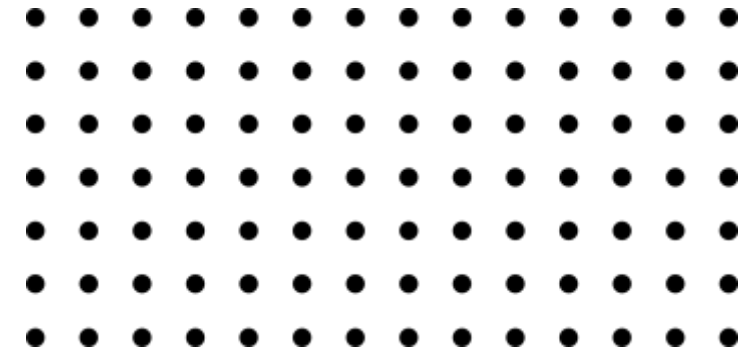

SEMI Parts- ALN & Y2O3

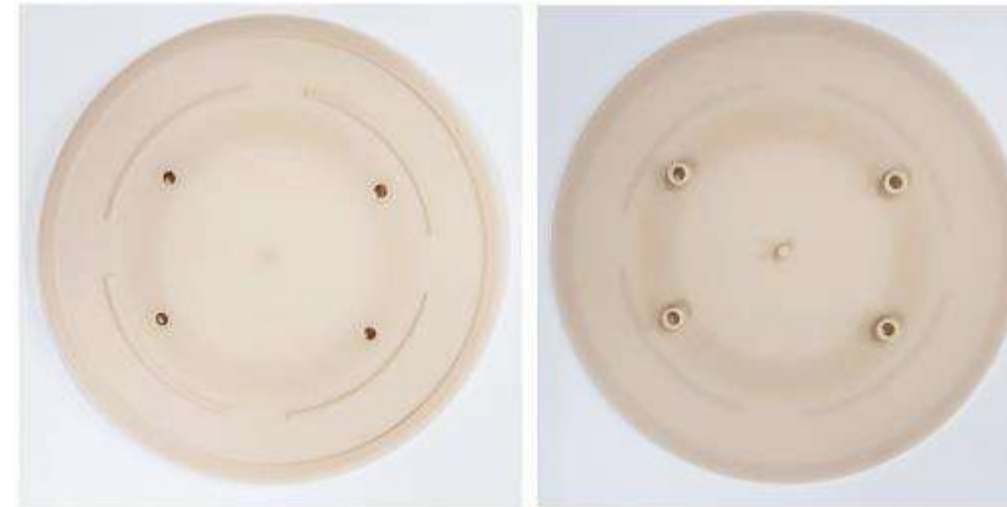
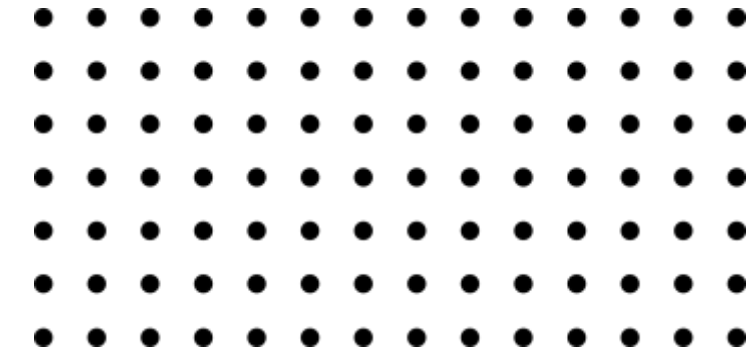

AIN BRACKET NOZZLE



DXZ COVER PLATE 0200-36629

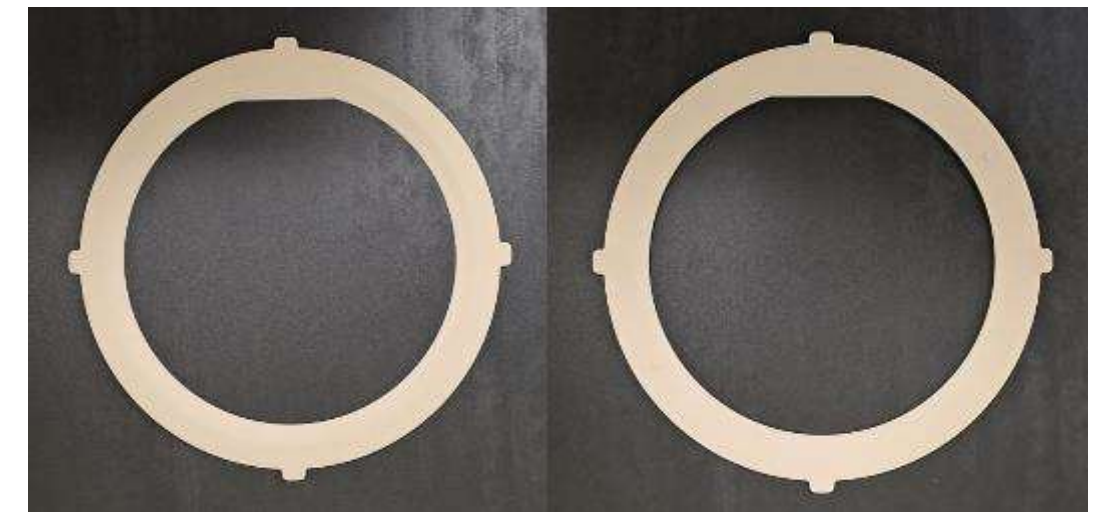

SHADOW RING_0200-04302

SEMI Parts-RTP

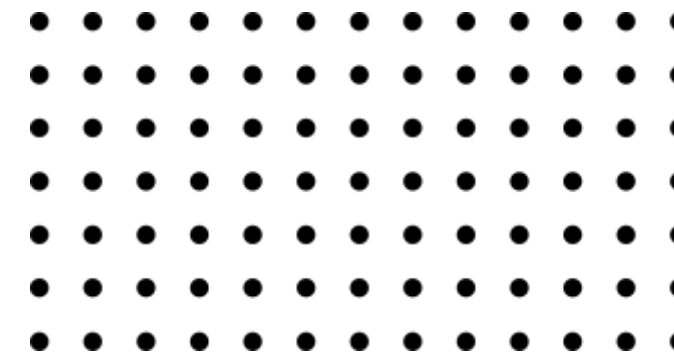

12" AMAT UNI-Ring
0200-23001
0200-23002
0200-02917

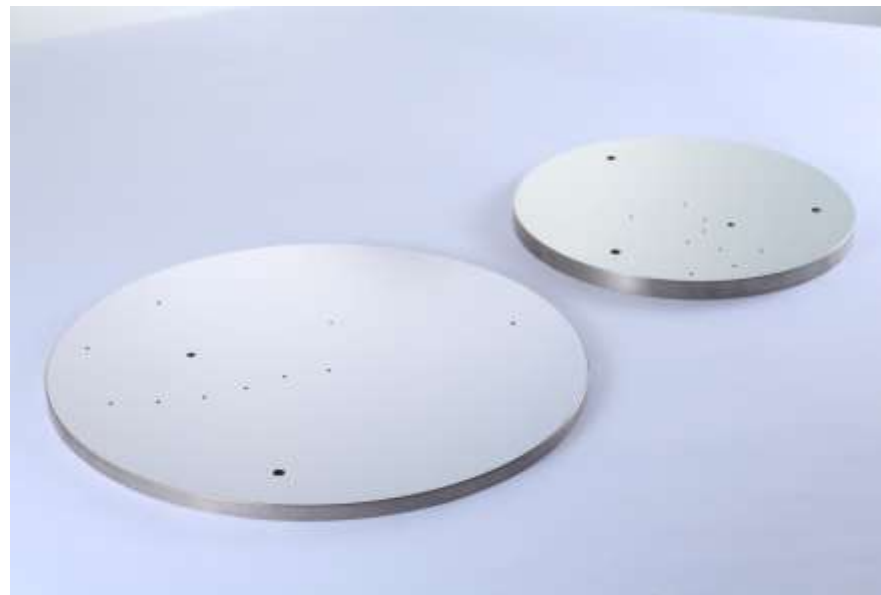

12" AMAT Reflector Plate
0041-12192
0041-12156
0041-39482

12" AMAT Susceptor
0200-01947

12" AMAT Support Cylinder
0200-15617
0200-04094



12" AMAT Lamp Taper
0021-36086
0021-35055
0020-01419

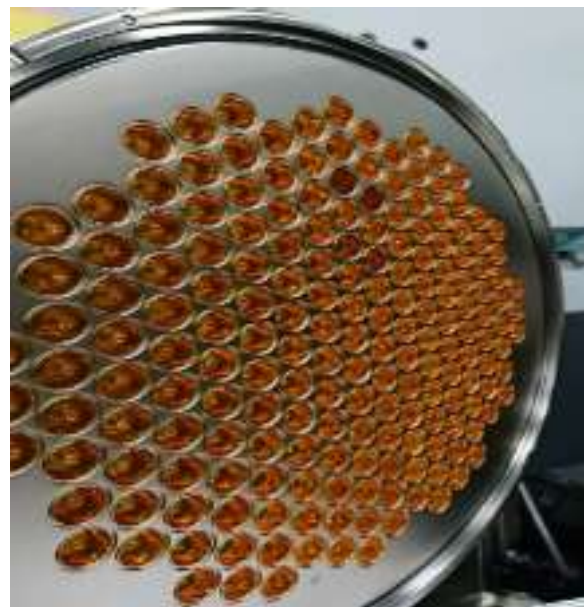

12" AMAT Lamp Housing
0040-88855
0040-70247



12" AMAT Lamp
0190-38516
0190-38517

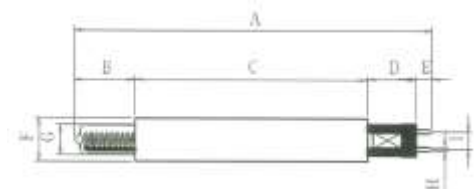

SEMI Parts-Wet



12" DNS Spin Base
3100/3200/3300
6A61060701



12" DNS Chuck Pin
6A610608

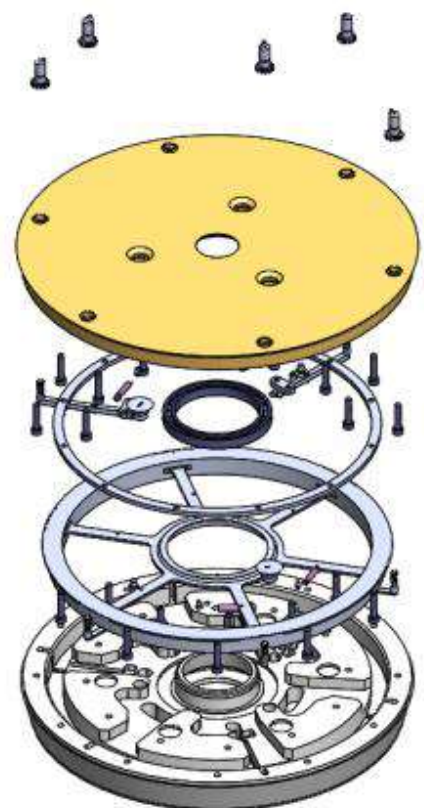

12" Lam Spin Base
853-109087-262
853-109087-201

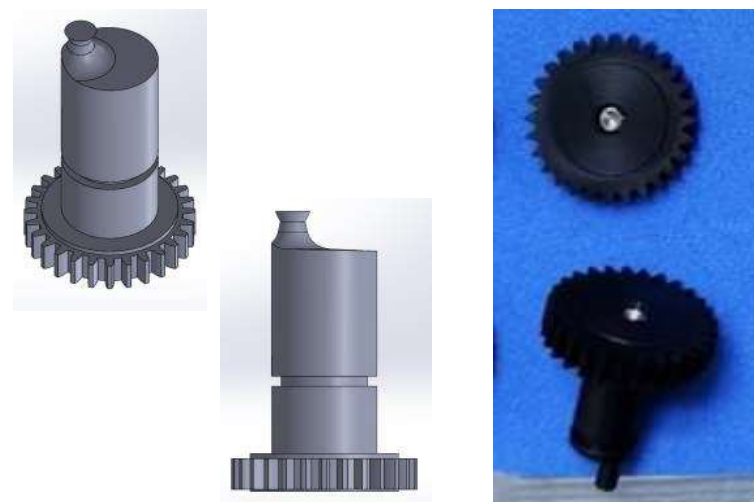

12" Lam Chuck Pin
2360570-01



12" ACM Chuck Pin
506-0065



Test Tool

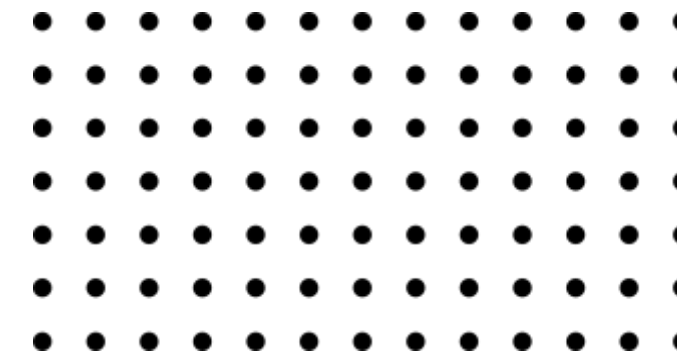

LCD/AMOLED Parts- Lamp & Clamp & Other

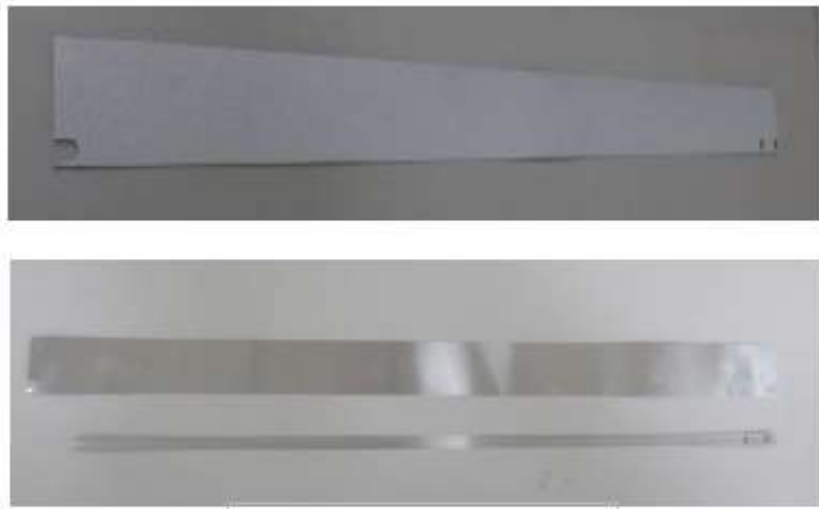

Grounding line(AL/NiCr 합금)



Display Parts-Pad



액정 잉크젯 헤드



Probe Pin



PVD-Clamp



Display Parts-Lift pin



Lighting Lamp

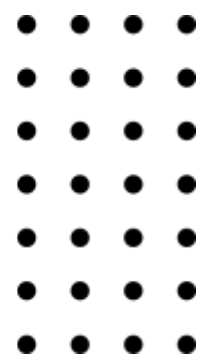

SEMI Maintenance service



CO2 DIW water system



Dry Ultrasonic Clean

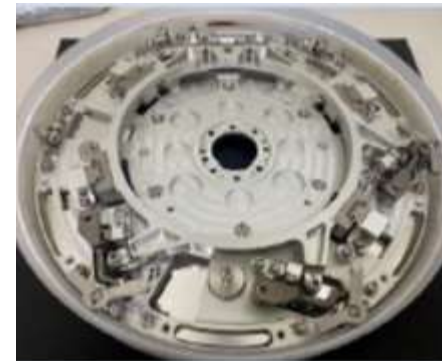

Spin Chunk



SEMI Maintenance service

BARATRON Gauge

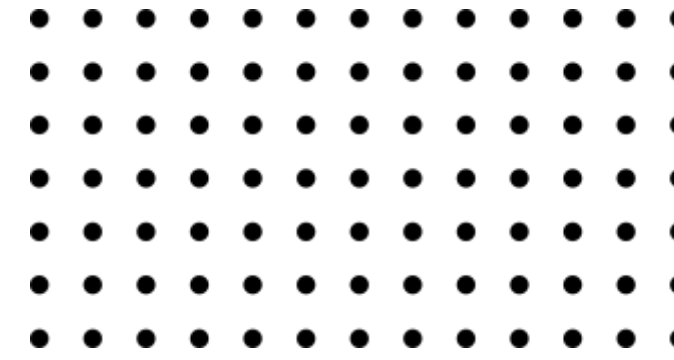

4x / 5x Series



600 Series



700 Series



E2x Series



Test Tool

LCD/AMOLED Parts-Ceramic & Mask & Other

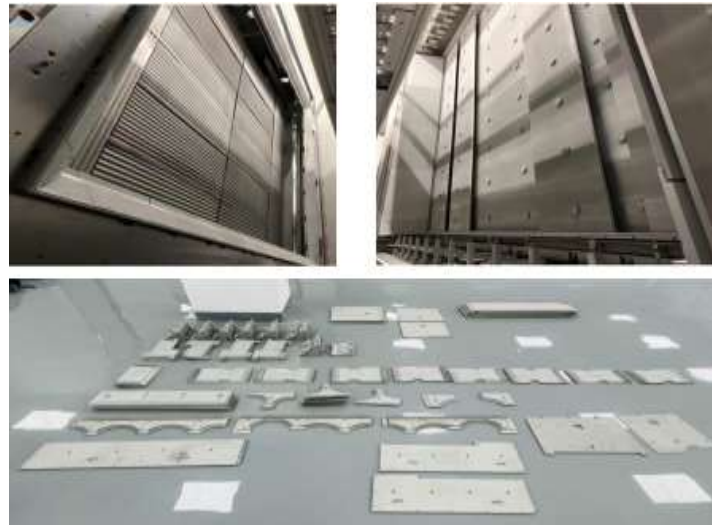

PVD-Mask



대형Plate



Golf tee & Bushing set



Adapter



Carrier Car



Carrier Holder

SEMI / LCD / AMOLED Maintenance service

-Chiller



AMAT



NESLAB STEELH...



NESLAB HX-150



NESLAB M33



Julabo FC1600T



NESLAB SYSTEM3



HB-THERM HB-W...



Thermo CUBE



TAITEC CH-800B



EDWARDS TCU4...



ATS DEX-20A



Daikin DI MAX



SMC HRZ001-L-D



SMC HRG001-W-A



SMC H-2000 INR...



Daikin UBPR3AM...



ATS NX-20A-GL



ATS M-PAK

SEMI/LCD/AMOLED Maintenance service

-MB/ RF/ MOTOR/ MKS/VALVES



MOTOR



RF Power Supply



MKS RPSC 2~30L

SEMI / LCD / AMOLED Maintenance service

- VALVE / CDU / PUMP 에너지절약

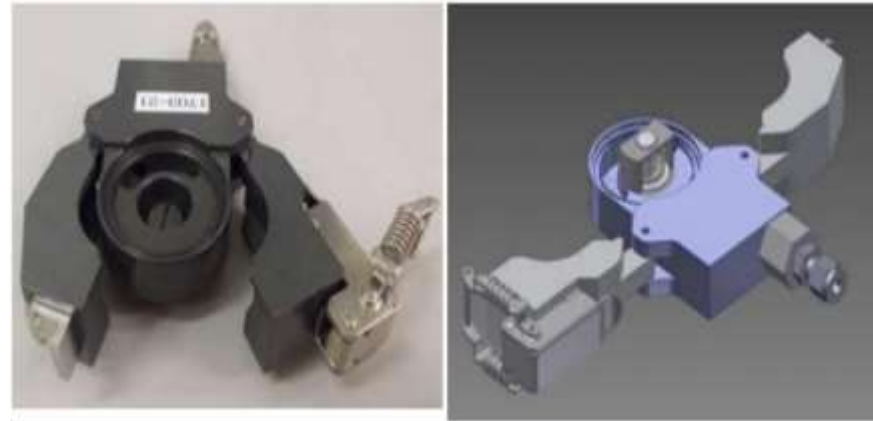

Pump 에너지절약

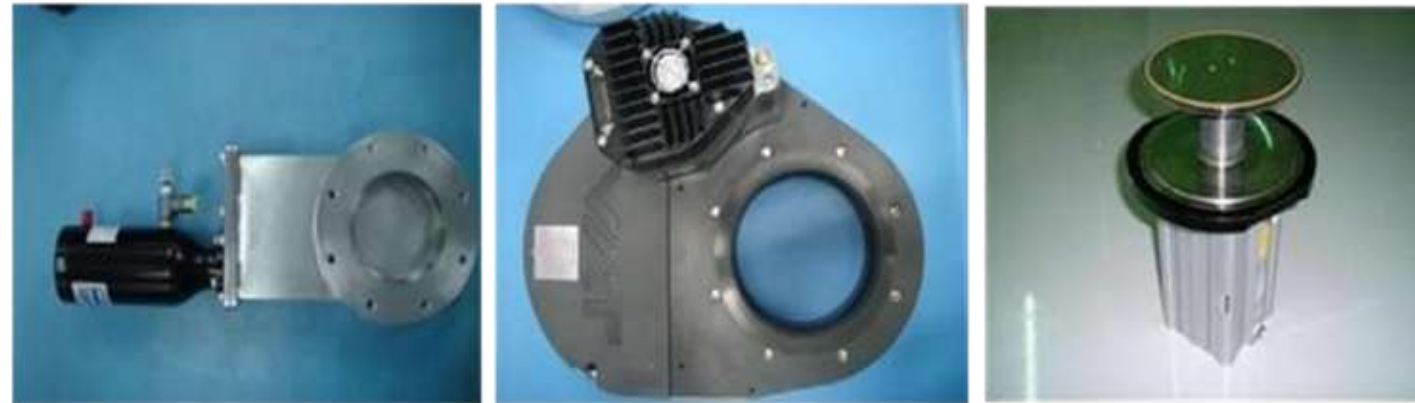

Gate valve



SDT Surge Protection



CDU/RDU



SEMI / LCD / AMOLED Maintenance service

-Turbo & Cryo PUMP

Suzuki型	型號系列	Aisin型	型號系列		
	A-100 Lseries		SA-08FA-11 series		
	A-150 series		SA-10FI-11 series		
	A-200 series		SA-12FA-11 series		
	A-200F series		SA-06SJ-11 series		
	A-250F series		SA-08SJ-11 series		
	A-300 series		SA-10SI-11 series		
	A-300F series		SA-12SA-11 series		
	A-350 series		SA-14SJ-11 series		
	A-400 series		SA-16SJ-11 series		
	A-550 series				
	A-570 series				
CTI 型	型號系列	ULVAC 型	型號系列		
	CT-8		CRYO-U4H		
	CT-8F		CRYO-U6H		
	OB-8		CRYO-U8H		
	CT-10		CRYO-U10H		
	OB-10		CRYO-U12H		
	CT-250F		CRYO-U16		
	OB-250F		CRYO-U20P		
	CT-250F				
	CT-400				
	OB-400				



SEMI / LCD / AMOLED Maintenance service

– Turbo PUMP



 **SHIMADZU**

- 303 ▪ 403 ▪ 803 ▪ 1003 ▪ 1303
- 1503 ▪ 2203 ▪ 2403 ▪ 2404 ▪ 2804
- 3203 ▪ 3403 ▪ 3413 ▪ 3804 ▪ 4304 ▪ V1704
- V2304 ▪ V3304 ▪ W2403 ▪ W3503 ▪ H3603



 **EDWARDS**

- 1303 ▪ 1603 ▪ A2203 ▪ A2503 ▪ A3503
- XA2703 ▪ XA3203
- XA4503 ▪ IXA2206 ▪ IXA3306



SEMI / LCD / AMOLED Maintenance service



Seiko Seiki Pump



Shimadzu Pump

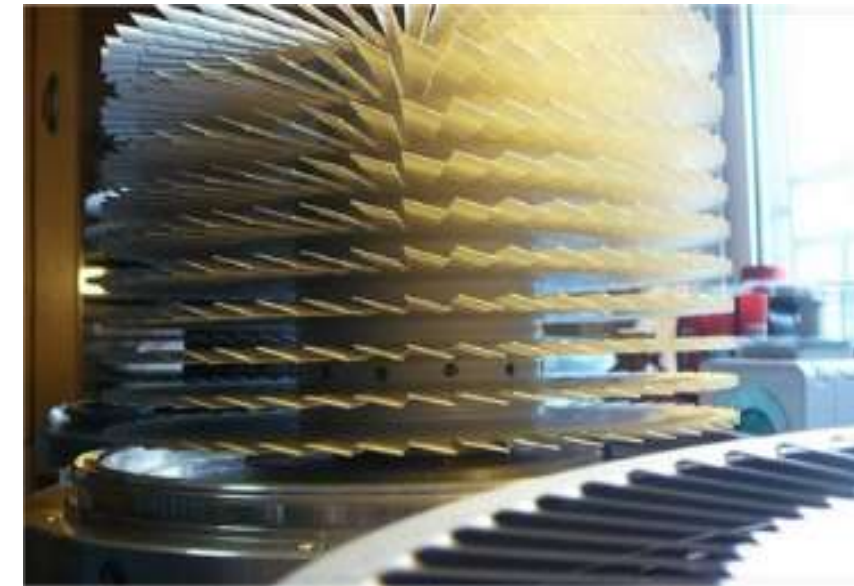

Mitsubishi Pump

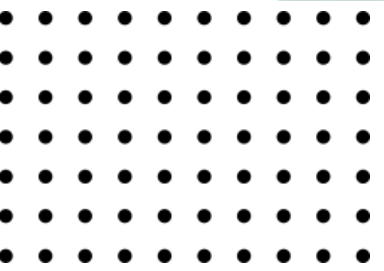

Transformation of equipment and system



AMHS OHT



AMHS STK



무풍식 이본바



점등기

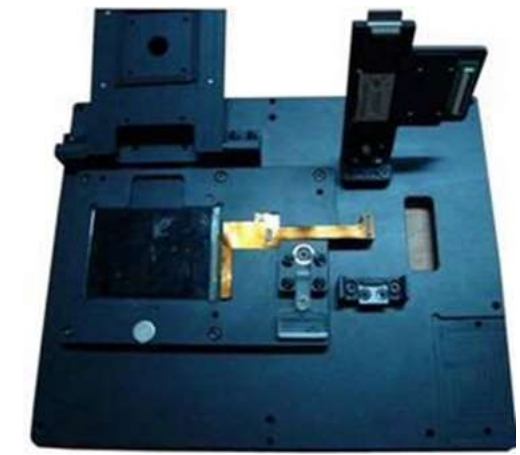

Probe Pin

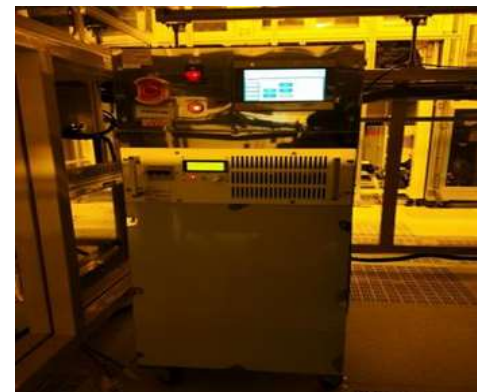

PVD-Clamp

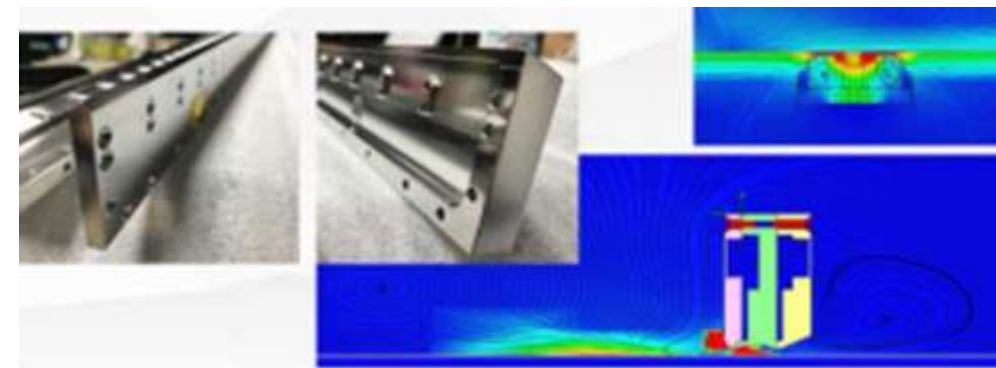
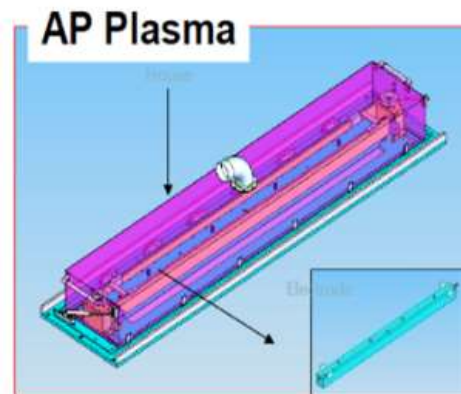

Display Parts-Lift pin



Lighting Lamp

Total Solution in Water treatment engineering



We Provide:

Water system Evaluation, Basic design, Detail Design, Installation, Testing, Operation and Maintenance.



Service Include:

DI water supply system, Wastewater treatment system, Wastewater Reclaim system.



Application Field:

Include most industry in Semi-conductor, LCD, Solar cell, LED, PCB, Mechanical, Medicine etc.

Water treatment engineering

DI water system

Grade: RO water/
DIW/UPW

- Pre-treat Unit: MMF/ACF/SF
- Further-treat Unit: 2B3T/RO /MB/EDI
- Post-treat Unit: UV/Polisher/MD/UF



MMF+ACF



CEDI



RO



2B3T



UV/Polisher

Water treatment engineering

Wastewater system

- Chemical Reaction Treatment: HF wastewater/As wastewater/Heavy-metal wastewater.
- Bio-treatment: UASB, A/O, MBR, Contact aerator.
- NH₃ treatment: Membrane separation, High-G Stripper, Electrolysis oxidation



HF Batch Reactor



Chemical Sedimentation



High-G stripper



NH₃ Membrane separation unit



As Batch Reactor



UASB



MBR

Water treatment engineering

Wastewater Reclaim system

- Inorganic Wastewater Reclaim: MMF/ACF/UF +RO °
- Organic Wastewater Reclaim : MBR + RO



UF/RO



MMF



MBR- Submerged type



MBR- Tube type



UF

Equipment - Olympus wafer inspection and review system



AW5000



Full Auto

FR3200



Semi Auto

AL3300



Semi Auto

AMAT Robot : XP service

AMAT XP Robot overhaul

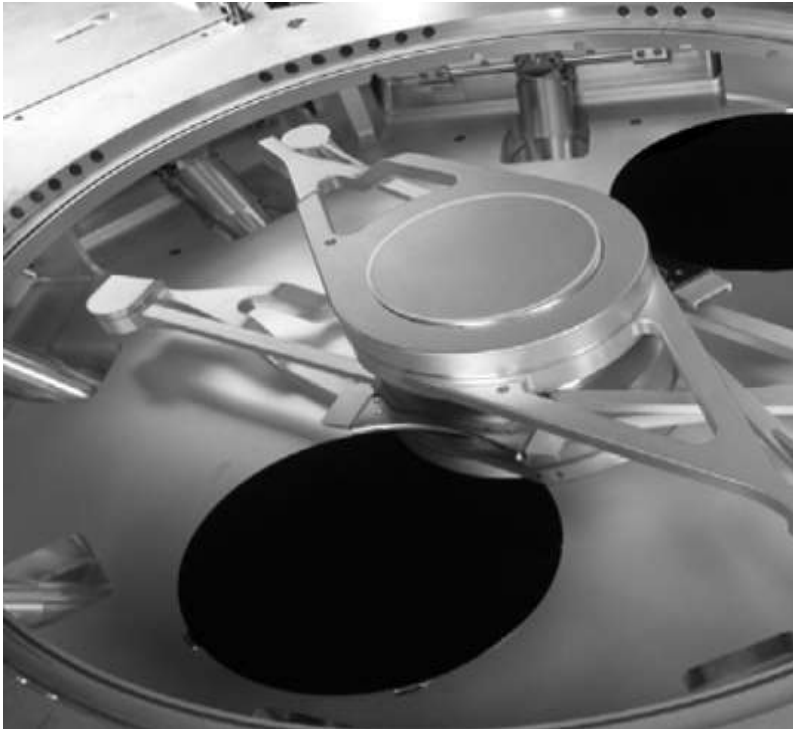
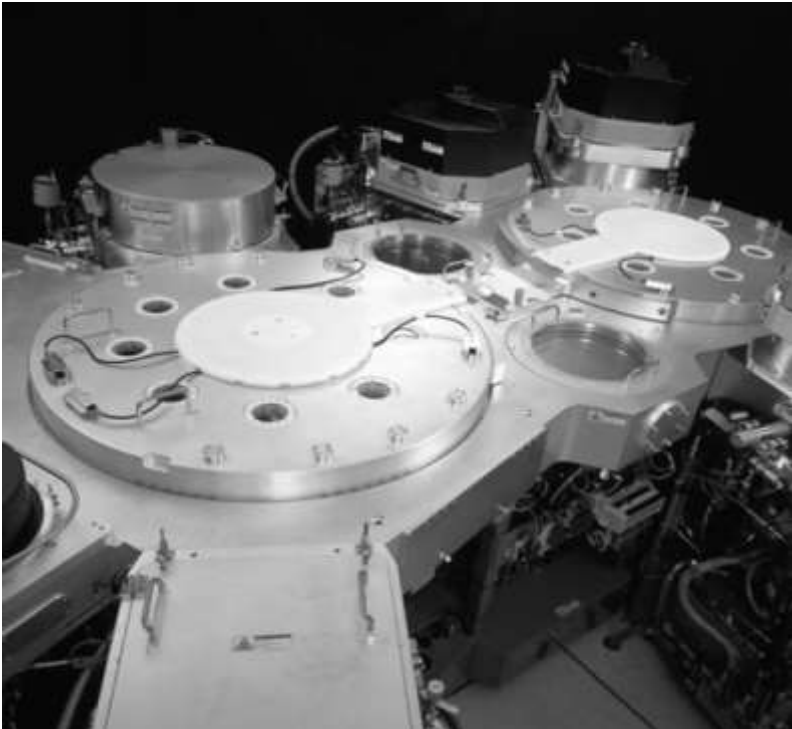

XP Robot Service :
1.Overhaul
2.Exchange

HP Robot Test Platform

Test Platform 이용하여 Applied Material 설비 robot 가동 상황을 확인 가능

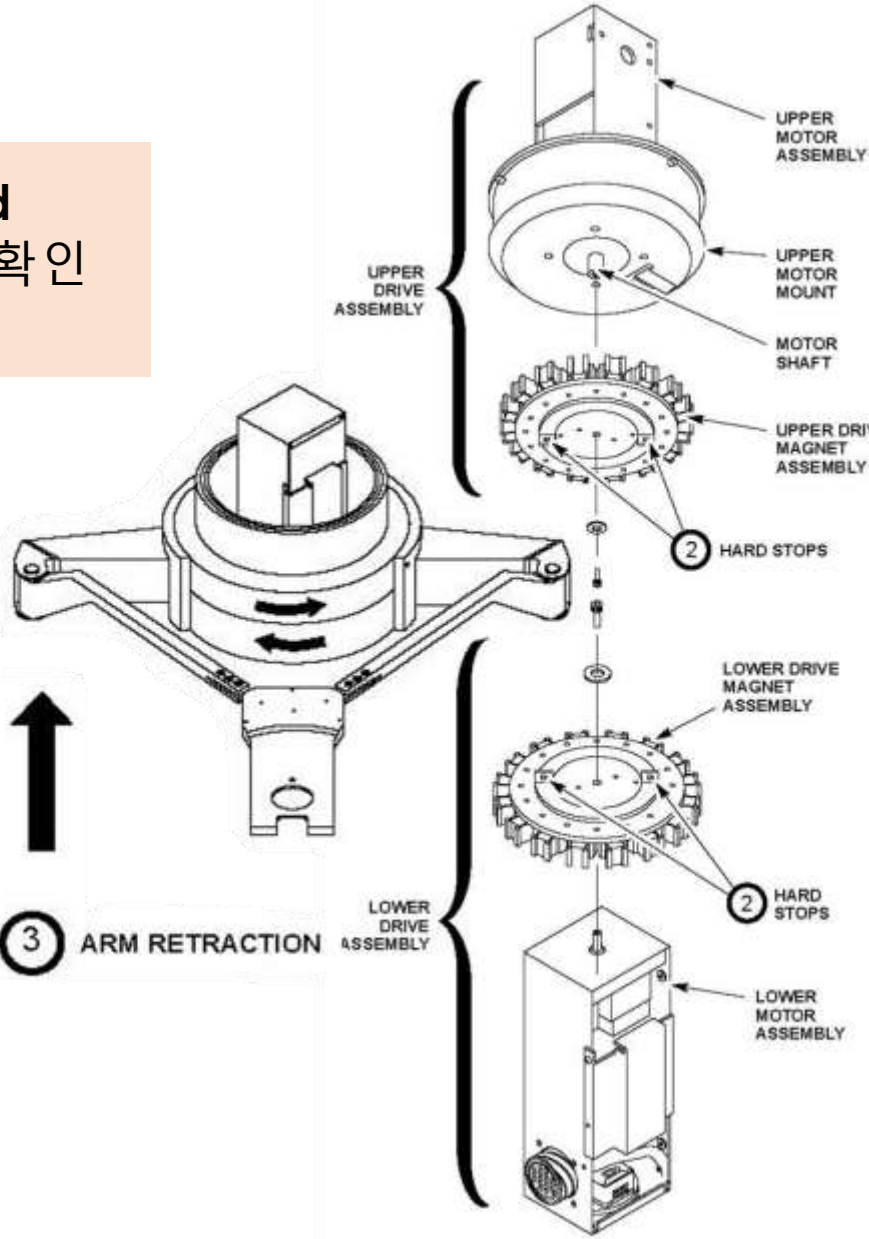

VHP Robot service

VHP Robot Overhaul
Presentation

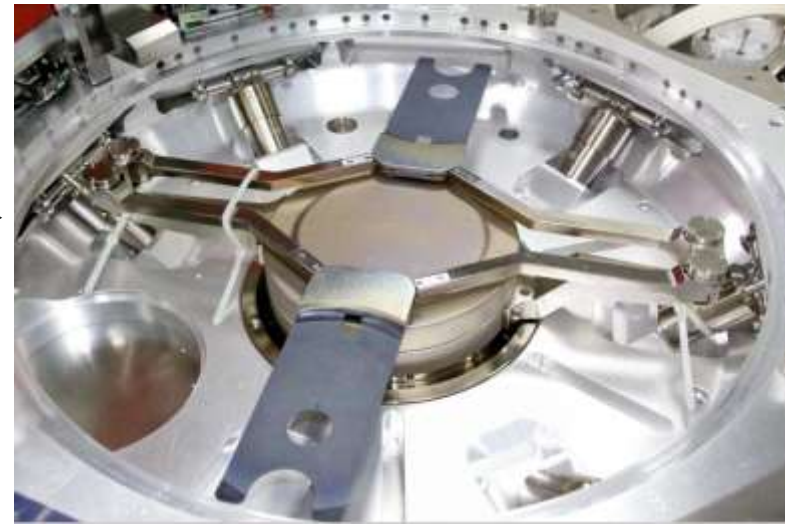

VHP Robot Armset



8" Centura type



Producer type



12" ETCH type

VHP Robot for 200mm &
300mm Tool

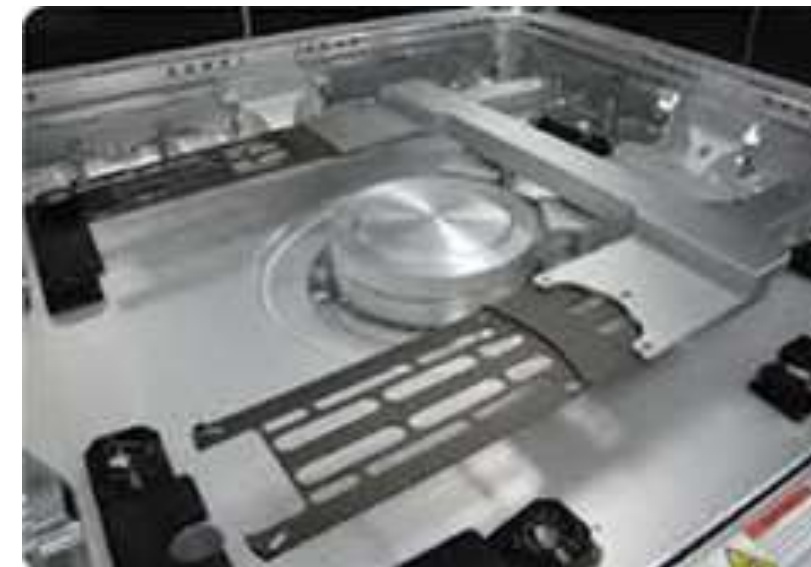

200mm tool ~
ETCH AMAT DPS
CVD AMAT HDP
CVD PRODUCER
PVD ENDURA tool
Transfer robot

300mm tool ~
ETCH AMAT EMAX
ETCH AMAT DPS2
CVD PRODUCER

HP Robot service

HP Robot
Introduction



HP Robot Service :
1.Overhaul
2.Exchange

적용 설비



Application : Centura-CVD, Endura- PVD
Etch-Mxp ,Super E ,DPS , HDP
Lead Time : 1~2 weeks
Warranty : 6 months

Adjust home sensor
feedback voltage

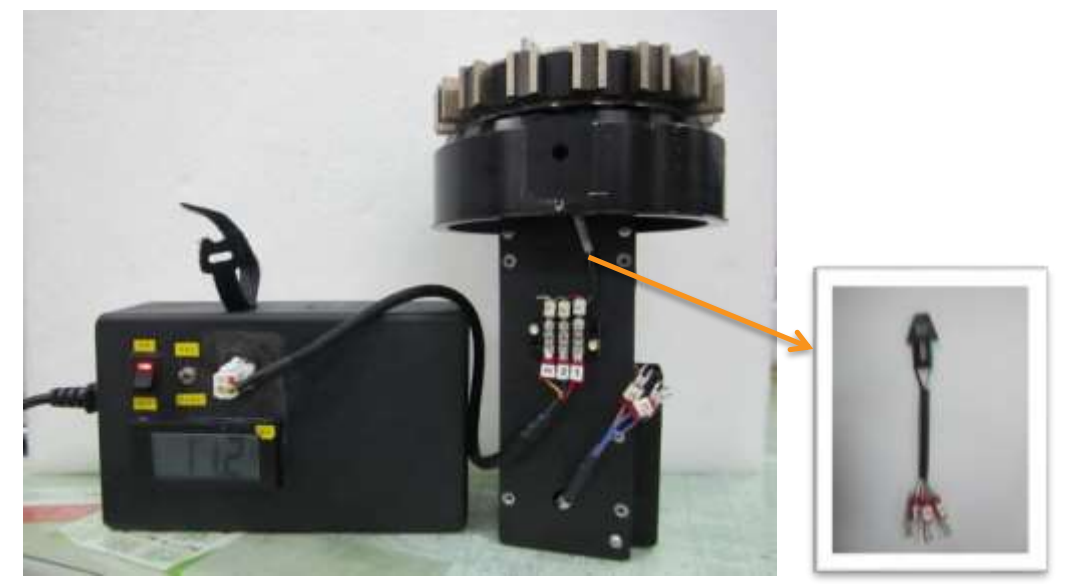

Measure sensor feedback voltage after
replace new sensor
Spec: < 1 voltage

Chemicals

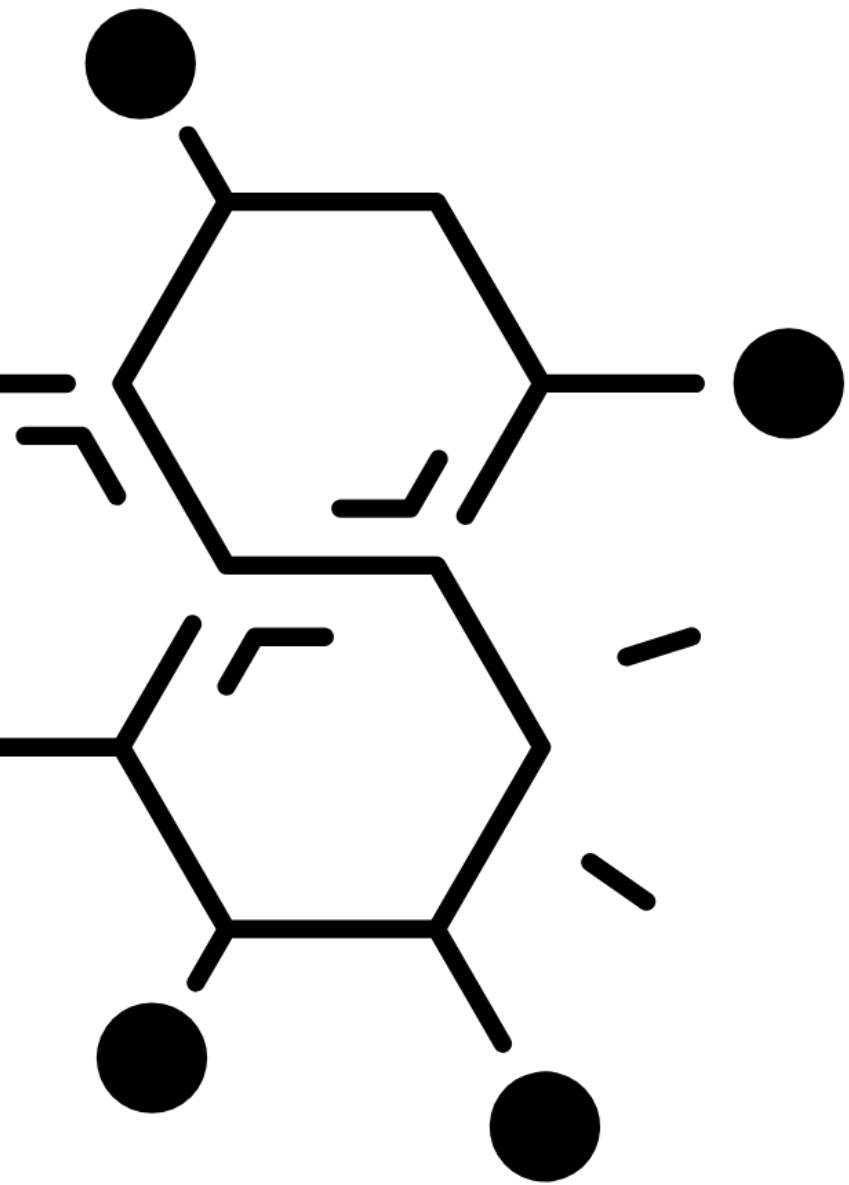

Group	Product name	Target thickness	Characteristic	
Semiconductor	KrF Photoresist	YKP-503	<ul style="list-style-type: none"> Thickness 0.54um (Res. 180nm, 250nm) Implant & Etch Layer 	
		YCKP-1654	<ul style="list-style-type: none"> Thickness 0.54um (Res. 180nm, 250nm) Implant & Etch Layer 	
		AYCKP-7930	<ul style="list-style-type: none"> Thickness 0.30um (Res.180nm) Implant Layer 	
		YKN-510	<ul style="list-style-type: none"> Thickness 0.54um (Res. 180nm, 250nm) Implant & Etch Layer 	
		YCKN-4530	<ul style="list-style-type: none"> Thickness 0.30um (Res.180nm) Implant Layer 	
		YCKN-2954	<ul style="list-style-type: none"> Thickness 0.54um (Res. 180nm, 250nm) Implant & Etch Layer 	
	TSV Thick Photoresist	YPP-T6K	6.0um	<ul style="list-style-type: none"> Thickness 6.0um (Res. 6.0um, Contact Hole) i-Line Positive TSV Devices
		AYCKP-9160	6.0um	<ul style="list-style-type: none"> Thickness 6.0um (Res. 5.0nm, Contact Hole) KrF Positive TSV Devices
	BARC	YCB-240	0.024um	<ul style="list-style-type: none"> Thickness 0.024um TSV package BARC – Ball grid array bumping process
		YA-400	0.04um	<ul style="list-style-type: none"> Thickness 0.04um ArF BARC
		YA-600A	0.06um	<ul style="list-style-type: none"> Thickness 0.06um Gapfill BARC
		YA-800	0.08um	<ul style="list-style-type: none"> Thickness 0.08um ArF BARC
TARC	YCTA-9047	0.43um	<ul style="list-style-type: none"> Environmentally safe; PFOS/PFOA issue free Low refractive index pH controllable 	

Chemicals

Group	Product name	Target thickness	Characteristic	
Semiconductor	Spin On Carbon Hardmask	YHS-80 / YHS-140 / YHS-330 / AYCHS-2819	0.08um 0.13um 0.33um 0.19um	<ul style="list-style-type: none"> High Tg Low defect density
		YCHS-130 / YCHE-3731 / YCHE-4359 / YCHE-20	0.2um 0.31um 0.59um 2.0um	<ul style="list-style-type: none"> High Tg, High etch resistant Low Fume High carbon content (more than 85 wt%)
		YCHS-3814	0.08um	<ul style="list-style-type: none"> Planarization SOC
		YS-210	0.21um	<ul style="list-style-type: none"> Thickness 0.21um Normal SOC
	CMP	NTS-300	-	<ul style="list-style-type: none"> Slurry for polishing semiconductor SiO₂/Poly/Nitride layer. Alternative of selective/non-selective polishing.
		YCHT-S902 / YCLW-S804		
		SW-300		<ul style="list-style-type: none"> CMP slurry for Tungsten buffing process W Removal Rate: ≥ 30 Å/min
		YPCC-2000	-	<ul style="list-style-type: none"> Contamination remove and corrosion control after the CMP process.

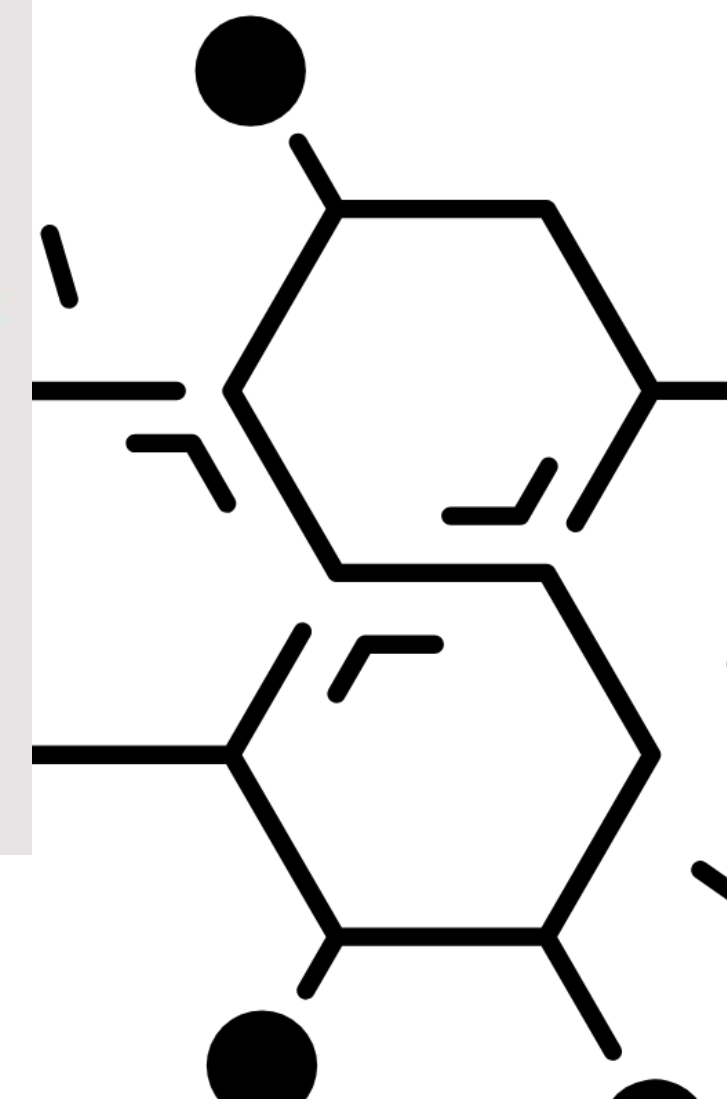

SAFETY GUARANTEE



● Xiamen GCT ISO 9001



● Xiamen GCT ISO 14001



● GCT ISO 9001 & ISO 14001



● GCT (JIANGSU) ISO 9001 & 14001



● SHT ISO 9001



● 위험물 화학 경영 허가

GLORY SUCCESSFUL Group



SUCCESSFUL HEART
TECHNOLOGY

SUCCESSFUL HEART
TECHNOLOGY CO.,LTD.



SINGAPORE
SUCCESSFUL HEART

SUCCESSFUL HEART
TECHNOLOGY
(SINGAPORE) PTE. LTD.



JAPAN
SUCCESSFUL HEART

SUCCESSFUL HEART
TECHNOLOGY (Japan)
PTE. LTD.



SUCCESSFUL HEART
VACUUM CO., LTD

SUCCESSFUL HEART
VACUMA CO.,LTD



GLORY CLOUDS

GLORY CLOUDS CO.,
LTD.



GLORY SUCCESSFUL

Xiamen GLORY CLOUDS
Tech
GLORY C.LOUDS (JIANGSU)
Tech



MCSZ CO.,LTD.



晶采電子商務股份有限公司
JCI E-commerce

JCI E-Commerce

Customers

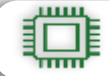

SEMI



UMC



nuvoTon
新唐科技



United Semi



CanSemi

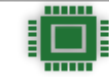

Packaging



LCD





Thank you.